



PETERSEN[®]
I N C O R P O R A T E D

"A Winning Combination."

FACILITIES/LOCATIONS

What started out in a garage in 1961 is today over 2 million square feet of world class manufacturing, specialized fabrication, precision machining, and warehouse/distribution facilities.

Our facilities located in Ogden, Utah and Pocatello, Idaho are equipped with the latest fabrication and machining equipment available. Situated at the base of the beautiful Wasatch Mountains, our corporate facility is located in Ogden, Utah just 40 miles north of the Salt Lake City International Airport, and has convenient interstate access to minimize transportation costs. Our facility in Pocatello is located by the Pocatello Airport which offers Delta connection service to Salt Lake City and worldwide.

With a strategic location for the western United States, we provide 3PL warehousing and distribution to customers worldwide. Our warehousing facility is located just one mile east of Interstate 15 and equipped with rail access.



Corporate Facility, Ogden, UT



Warehousing Facility, Ogden, UT



Idaho Facility, Pocatello, ID

100% ESOP
Employee Owned Company





Reactor and Cycle X- Flying J



Column- Chevron



Skid Mounted Pipe Spools

INTRODUCTION

WELCOME TO THE LAND OF THE GIANTS

Founded in 1961 and incorporated in Utah in 1980, Petersen Inc. is one of the foremost advanced manufacturing facilities in the United States, serving customers throughout the world. With modern capabilities and open capacity, we effectively serve industry giants like Bechtel, Boeing, CB&I/Areva, Chevron, Disney, Energy Solutions, Flying-J, Fluor, GE Hitachi, JBT, Lockheed Martin, NAC International, Northrup Grumman, Nuclear Waste Partnership LLC, Rio Tinto, Setpoint, Timet, Universal Studios, Westinghouse and others.

Petersen Inc. offers complete fabrication, advanced manufacturing, and machining services that are ideal for nuclear, petrochemical, aerospace, mining and industrial projects, equipment and parts.

Our team is dedicated to creating quality, on-time products and complete customer satisfaction. For a safe, reliable, and financially secure partner, Petersen Inc. is your source for success.

- Advanced Manufacturing
- Precision Machining
- Custom Fabrication

- Design Engineering
- Warehousing / Distribution
- Field Services



NUCLEAR FABRICATION

Petersen Inc. manufactures nuclear process equipment, storage containers, gloveboxes and Melters for Department of Energy projects including the Hanford Waste Treatment Plant, Savannah River MOX facility, WIPP and more. Additionally, many clean-up, demolition and disposal projects have contracted with Petersen Inc. to produce process equipment to support safety and proper storage of radioactive material.

The Rod Storage Racks were comprised of many components that are assembled into structural, mechanical, and electrical subassemblies. Each unit includes gloveboxes used for the confinement of nuclear materials, mechanical equipment for movement of nuclear materials, and electrical equipment (including actuators, sensors, and controllers) used for monitoring and control of the Rod Storage Racks equipment and operations.

The HLW and LAW Melters are designed to handle upwards of 53 million gallons of radioactive waste. Pretreated liquid waste from underground storage tanks is combined with glass forming materials in the Melter and heated to 2100°F. The molten liquid glass is poured out of the Melter into specially designed containers, allowing the glass to cool or solidify prior to being shipped and stored in a much safer condition. The Melters cannot be turned off once the process is started so the reliability of the Melters is crucial to the success of the waste cleanup.

HLW - 30 major components with hundreds of sub-assemblies
~ Dimensions: 14'W x 14'L x 15'H
The base, walls and lid weigh 26-tons.

LAW - 60 major components with hundreds of sub-assemblies.
~ Dimensions: 21'W x 30'L x 19'H
The base, walls and lid weigh 150-tons.



Rod Storage Rack – CB&I Areva MOX Services



HLW Melter- Bechtel National



SWB

TDOP

RLC

Shield Plug

NUCLEAR MANUFACTURING

Petersen Inc. is a major manufacturer of containers for many industries including nuclear, aerospace, commercial, and petrochemical. We are proud to be a part of the clean-up of waste generator sites around the country, helping to make it a cleaner and safer environment for future generations. We fabricate RLC's, SWB's and TDOP's for the Department of Energy. They are stored at the WIPP site, 2150 feet below the surface in the Permian Salt Formations.

PETERSEN INC. MANUFACTURED CONTAINERS/CASKS:

- Ten-Drum Over-Pack (TDOP)
- Standard Waste Box (SWB)
- Standard Large Box (SLB)
- IP-2 Type 1 Cargo Container (20' and 23')
- Casks
- Removable Lid Canister (RLC)
- Lead-lined Casks
- DOT Strong Tight Packages
- Shield Plugs
- Transportation Cask



Glovebox- Bechtel National

YOUR NQA-1 COMPLIANT SOURCE FOR NUCLEAR FABRICATION, MACHINING AND ENGINEERING.

- Gloveboxes
 - Hot Cells
 - Processing Equipment
 - Spent Fuel Casks
- Petersen Inc. provides high quality nuclear glovebox equipment for the nuclear industry and supporting facilities, providing a safe and controlled processing and handling system for nuclear products.

SPENT FUEL

Petersen Inc. is an industry leader in the manufacturing of spent fuel storage casks, including lead-lined casks. Spent fuel refers to nuclear fuel elements that have been used at commercial nuclear reactors, but are no longer capable of economically sustaining a nuclear reaction. This spent nuclear fuel then needs to be replaced, properly stored and properly disposed of. Companies have relied on us to produce high quality containment products for safe, reliable storage of spent fuel. Our in-house proven quality systems ensure that your products are being manufactured to the highest standards in the industry.

Petersen Inc. offers state-of-the-art facilities specializing in the manufacturing of process equipment, transportation equipment, special handling and monitoring equipment, as well as spent fuel containment containers and casks of all sizes. We also offer experience in providing custom manufactured equipment for decommissioning projects. Our safe, customer friendly environment allows the Petersen Inc. team the ability to interface and work alongside our customers' team on a daily basis. We welcome on-site support.

5

Notable projects on our resume include:

- | | |
|----------------------------|---|
| Energy Solutions- | First 3-60B Transportation Cask,
MIDUS _{TM} Type B Packages |
| GE Hitachi- | Fuel Pool Monitoring Systems, Handling Equip.
Steam Dryers, Nuclear Reactor Services Parts |
| NAC International- | Magnastor, Casks, Handling Equipment |
| Nuclear Waste Partnership- | SWB's, TDOP's, RLC's |

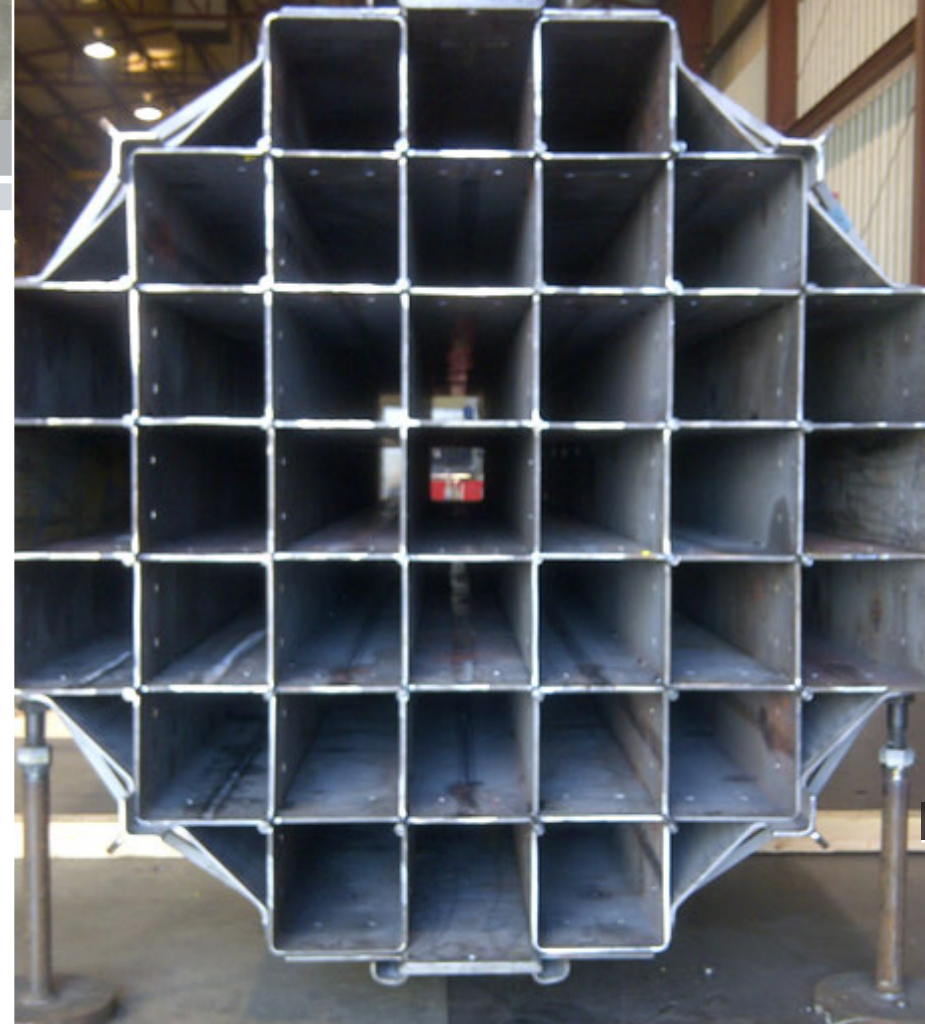

Internal Basket- NAC International



Efficacy Pad- West Valley Demonstration Project



Dryer- GE Hitachi



3-60B- Energy Solutions

NUCLEAR REACTOR SERVICES

With years of experience in commercial nuclear reactor services, Petersen Inc. is equipped to safely handle your radioactive treatment needs. We continue to provide ongoing safe solutions to high-profile projects with the Department of Energy, utilities, and nuclear related customers. Our planning and expertise ensures timely service, successful project implementation and execution for our clients. Petersen Inc.'s quality standards have been evaluated and approved by the following customers:

- Battelle Energy Alliance
- Bechtel Marine Propulsion
- Bechtel National
- Boeing
- CB&I Areva MOX LLC
- Energy Solutions
- Fluor Marine Propulsion
- GE Hitachi
- Honeywell
- Howden
- Idaho National Laboratory (INL)
- Jacobs
- Los Alamos National Laboratory
- NAC International
- Nuclear Waste Partnership, LLC
- Oak Ridge National Laboratory
- Westinghouse Electric Co.
- Westinghouse Savannah River Co.
- Zion Solutions (Energy Solutions)



MANUFACTURING/FABRICATION

MANUFACTURING

Petersen Inc. is an industry leader in custom fabrication and precision machining. With commitment to total customer satisfaction and sound financial strength, we have recruited the top talent in the industry. Housed in modern manufacturing and machining facilities, we provide state-of-the-art equipment, with heavy lifting 75-ton overhead crane capacity and 35' under the hook, which allows handling of virtually any project. We also offer heavy rolling and forming capabilities, as well as 5-axis waterjet and machining capabilities.

7

FABRICATION

Our fabrication and machining personnel are experienced in safely working with a variety of metals including stainless, aluminum, nickel, inconel, titanium, zirconium and carbon steel. We are a full-service company that focuses on fabrication, ASME code work, piping, vessels, containers, casks, and AISC certified structural work. We provide project management in a variety of fields including aerospace, industrial, mining, nuclear and petrochemical. When your applications call for custom fabricated equipment, tooling, or ground support equipment, Petersen Inc. can provide turn-key solutions.



Fabricated Mining Equipment



Fabricated 200' column

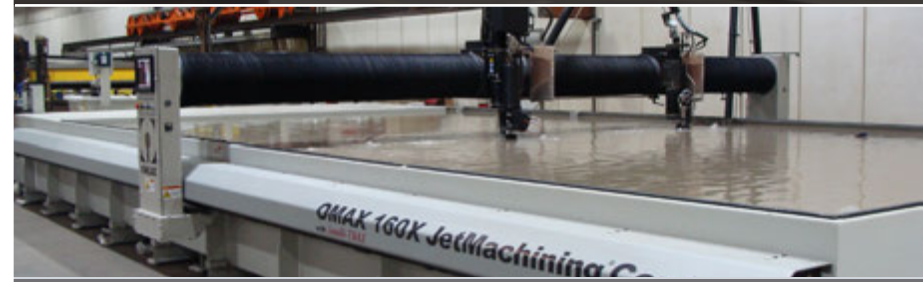

5-Axis Waterjet



Fabricated Refinery Vessel



Trommel- Goodfellow



Mining Boom- Komatsu



Castor Rocket Motor- Northrup Grumman

MANUFACTURING/FABRICATION

Petersen Inc. is a full-service fabrication and integration company providing design engineering, fabrication, precision machining, field services and 3PL warehousing/distribution services. We have extensive experience in the fabrication and assembly of modules including design, contractibility, procurement, project management, scheduling, and transporting products to their end destination.

We set ourselves apart from the competition by providing our customers with true quality workmanship and superior customer service, holding ASME 'U', 'U2', 'S', and NBIC 'R' stamps certifying the fabrication or repair of ASME pressure vessels at the facility or in the field. Products include pressure vessels (ranging from 4 inches thick to 24 feet OD), separators, skimmers, skids and scrubbers.

Time is money. That is why we dedicate our resources to on-time delivery and maintain the highest quality products in the industries we serve. Judge us by the company we keep!



LARGE PRECISION MACHINING

LARGE PRECISION MACHINING

At Petersen Inc. we offer a wide range of CNC milling and turning capabilities including 5 axis machining. Our experienced engineers, programmers, and machinists are some of the finest skilled craftsmen in the industry. Our milling capabilities range from small, detail machining to large 12' x 66' horizontal machining, and our turning capabilities range from small parts you can hold in your hand to 15' diameter to 10' under the rail.

Our winning combination of modern equipment, technology, and lean manufacturing techniques allows our team to successfully produce close tolerance components. We continually invest in modern, state-of-the-art equipment as well as facility upgrades to allow us to produce high quality precision machined components. We recognize the importance of maintaining the highest quality standards found in the industry, as well as being priced competitively.

9

INDUSTRIES SERVED

- Aerospace
- Amusement Parks
- Commercial Aviation
- Defense
- Food Service
- Hydro
- Industrial
- Medical
- Mining
- Nuclear/Energy
- Petrochemical
- Transportation

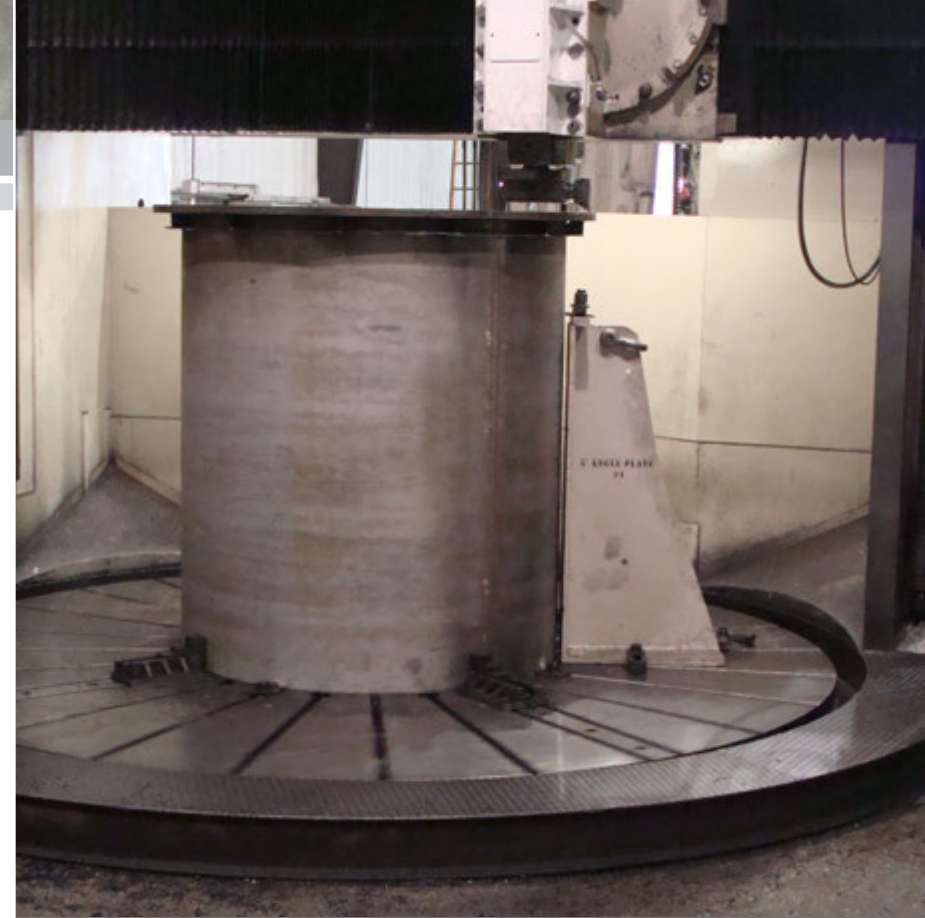

15' Diameter VTL



40 Ton Break Up Point- Western Zirconium



CNC Horizontal- Polyjet Valve



CNC Turning- 8' Diameter



Gray Horizontal 12' x 66' CNC



Mining Boom- Komatsu

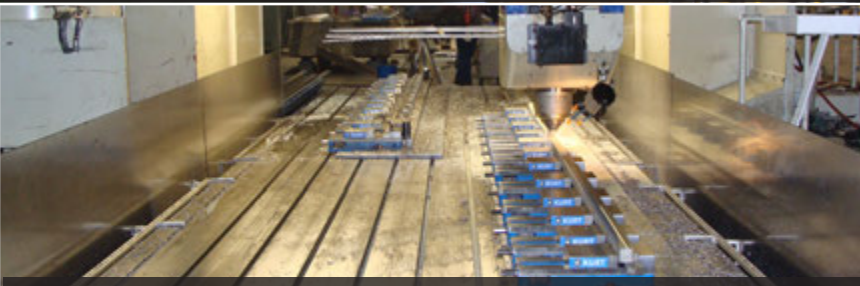

Gantry Mill 6'6" x 22'

LARGE PRECISION MACHINING

Our large precision machining capabilities are some of the largest available in the Western United States. Our experienced team includes highly skilled craftsmen, programmers, toolmakers, and machine operators who are capable of meeting your requirements.

- Multi-axis CNC machining
- CNC Horizontal Milling- 12' x 66'
- CNC Turning- 15' diameter 10' under rail
- Horizontal Boring
- Laser tracking
- Gantry Mills
- Large Lathes
- Drilling
- Surface Finishing

Quality products are the expectation of all customers. Petersen Inc.'s quality system includes an in-house commercial grade dedication lab and certified inspectors. Not only do we machine large components, we also have inspection capabilities to perform dimensional inspection. We use calibrated laser tracking systems and FaroArms to perform these inspections. This ensures our customers that we will meet and exceed their expectations. Petersen Inc. is currently ISO 9001-2015 certified, AS9100D certified, and NQA-1 compliant.



SMALL PRECISION MACHINING

Petersen Inc.'s climate controlled facilities provide capabilities that extend far beyond machining. We're also capable of designing and building plastic injection molds, die assemblies and precision components. Quality precision machined parts are the expectation of all our customers. Petersen Inc.'s quality system includes an in-house metrology lab and certified inspectors. The latest validation equipment ensures the best measurement possible. Our modern CNC machines allow us to produce precision products ranging from multi-axis up to and including 5-axis. Let us be your source for your small precision machining needs.



Small Precision Machining Facility

11

- 5-Axis Machining
- CNC Milling
- CNC Turning
- EDM (Wire & Sinker- both 12" cubed)
- 5 Axis Waterjet
- Surface Grinding
- ID/OD Grinding
- Black Oxide Surface Treatment
- Heat Treat
- Hollow Spindle Lathes

ADDITIONAL SERVICES

- Dedicated QA Inspection Area
- CMM Inspection
- FaroArms
- Hardness Testing
- Height Gage
- Calibrated Inspection Equipment
- Black Oxide
- Part Marking
- Engineering Services
- CNC Programming
- Heat Treating
- Coatings



Plastic Machined Parts



Canister- INL

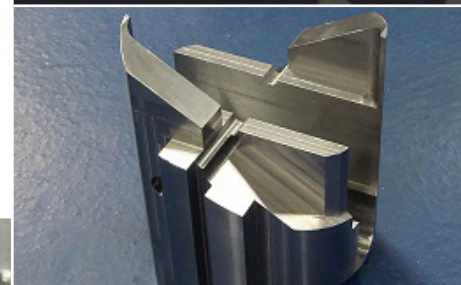

Ram Body- FHE



Mandrel

SMALL PRECISION MACHINING



While Petersen Inc. is intimately familiar with common tool steels and aluminum, it is no stranger to exotic materials:

- Aluminum Alloys 2014, 2024, 5052, 6061, 6063, 7050, 7075
- Tool Steels A2, D2, O1, S7, and most any other tool steels
- Stainless Steels: 303, 304, 316, 416, 440, 17-4, 15-5, Nitronic
- Inconel, Hastelloy, Waspaloy
- Titanium
- Alloy Steel 4130, 4140/42, 4330M, 4340, 8620, 52100, EN30B, A514
- 1018, 1045, 12L14, 11L17 steels
- Copper, Brass and Aluminum Bronze of any specifications
- Phenolic, Nylatron, Acetal, UHMW, Ultem, Teflon, Tefzel and almost any plastic
- Magnesium

FIELD SERVICES

THE ONLY MAINTENANCE TOOL YOU NEED

When you partner with Petersen Inc. you get an experienced and licensed maintenance and construction team.

- Turn-Key Solutions
- Facility Modifications
- Project Management
- Fabrication/Installation
- Comprehensive Plant Maintenance
- Experienced Millwrights

Want to lower your overhead expenses? Let our field service specialists come to your facility to perform a complete on-site analysis. Our field service team is among the top in the industry, and backed by talented manufacturing team members, as well as modern fabrication and machining facilities in Utah and Idaho.

INDUSTRIAL SHUTDOWNS – TIME IS MONEY

Our goal is to help you increase your bottom line. We want to be your partner in providing a safe, timely and affordable solution for your equipment or facility modifications, whether large or small. Our high quality standards allow us to satisfy our customers quality requirements.

Time is money, and the cost of downtime can quickly hinder your production and reputation. We focus on providing safe implementation, with a quick turnaround time, and total customer support throughout all phases of the project.



Stack - Ashgrove Cement



Plant Modification-
Solios/Ashgrove Cement



Plant Modification-
Pacific States Cast Iron Pipe



Vessel - Chromalox



Reactor and Cycle X - Flying J



Installation of Support System - Cycle X - Flying J

FIELD SERVICES

ON-SITE INSTALLATIONS - WHEN ONLY THE BEST WILL DO

With experienced millwrights and support personnel, Petersen Inc. can handle the simplest modifications to the largest plant expansions. We specialize in providing customers with turn-key solutions, fabrication and installations, rebuilds and plant maintenance. We are also able to be a specialty contractor providing solutions through on-time quality products for one or multiple phases of a project.

SAFETY - THE KEY TO OUR SUCCESS

Our reputation is directly related to the quality of our products. Behind that quality workmanship is a safe team network committed to providing the highest quality products. At Petersen Inc., every team member is an integral part of our safety and Human Performance (HUP) program.

Petersen Inc. is **COMMITTED TO SAFETY**, and continues to maintain a safety record below the national average. In our production facilities or on your site, we strive for continued safety excellence. Our customers are industry leaders who don't settle for second best, including:



DESIGN ENGINEERING

MULTI-DISCIPLINED ENGINEERING

Our Engineering Department is staffed with experts having over 175 years of combined excellence and experience in their respective fields. Using SolidWorks, CATIA, and AutoCad 3D modeling software, our staff provides design engineering, stress analysis, mechanical event simulation, value added engineering, project management and construction services to customers in a wide variety of industries. Specialized engineering functions include ASME Section VIII, Division 1 and 2 vessels and B31.1/ B31.3 piping, NQA-1 compliant design/build for nuclear applications and mechanical event simulation. Traditional finite element analysis is also accomplished to display stress levels and optimize structural configurations of your products. Physical container drop test certification capabilities using in-house drop pads and equipment are also offered.

15

3D MODELING

Our extensive 3D modeling capabilities can create tailored solutions to your design dilemmas. Complex assemblies are easily developed using these 3D tools to verify compliance with customer requirements, verify operating clearances, and confirm that no interference conditions exist. The same parametric 3D models can be very quickly converted to fabrication drawings prior to releasing them to the shop for manufacture.



Solid Rocket Booster M111 Work Platform designed, built and installed by Petersen Inc.- Northrup Grumman



Vessel Render



Amusement Lift Render

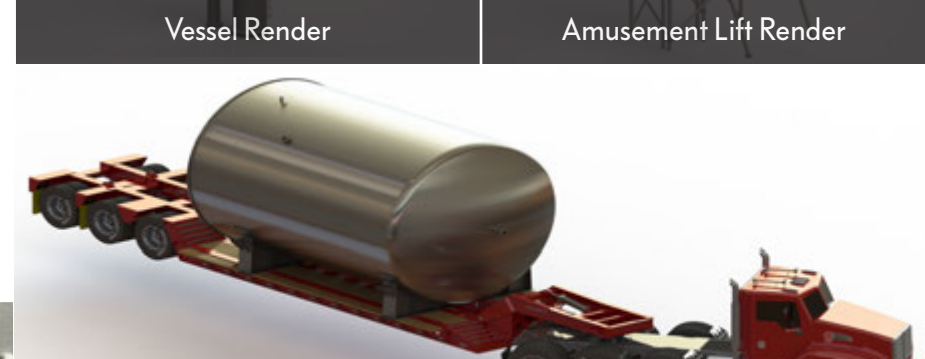

Transport Simulation Analysis

3 D MODELING

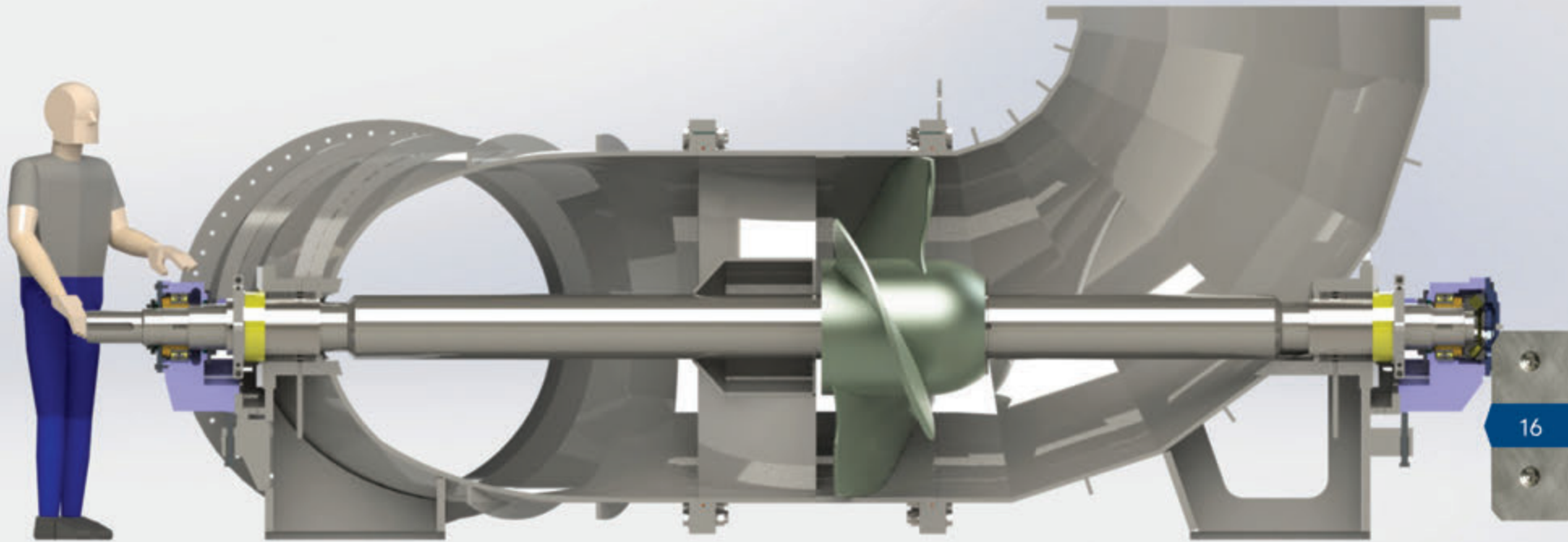

Petersen Inc. extensive 3D modeling capabilities can create tailored solutions to your design dilemmas.

- Form, Fit, and Function Analysis
- Model Based Definition
- NozzlePRO Paulin Research Group
- Large Scale 3D Scanning Capabilities
- Design Engineering
- SolidWorks PDM Professional
- Mechanical Event Simulation
- Value Engineering
- Certified Mechanical Engineering
- ANSYS Finite Element Analysis
- SolidWorks Premium
- SolidWorks Simulation Premium
- Autodesk Simulation
- Autodesk Product Design Suite
- Compress, by Codeware

WAREHOUSING/DISTRIBUTION

WE KNOW THIRD PARTY LOGISTICS

Petersen Inc. offers 3rd Party Logistic (3PL) services from the warehouse & distribution facilities in Ogden, Utah. We provide warehousing, fulfillment, kitting, distribution, packaging, inventory management, shipping, and operational support including surplus and excess property. For over two decades we have successfully managed all of Boeing's out-of-production commercial aviation tooling. In addition to the tooling, we manage over 3,000 service bulletin toolkits, and provide all of the engineering, manufacturing, and quality services required to ensure that the kits are current. We offer these services to a wide variety of industries.

Advantages

- 1.4 million sq. ft. warehousing facilities offer options from office space to storage
- Each building averages 300,000 flexible sq. ft.
- Bay sizes are 200 ft. x 200 ft. with firewalls and fire suppressant systems
- Strategic location for the western United States

High Security Storage

- Fenced property
- Secure buildings
- On-site security
- Video Surveillance
- Alarm system

Climate

- Low earthquake frequency
- Low humidity
- Moderate temperatures

Access

- One mile east of Interstate 15
- Rail access



Standardized Rack Storage



Narrow Opening Rack Storage



Service Bulletin Toolkit Storage



In-Process Service Bulletin Toolkit Inspection

WAREHOUSING/DISTRIBUTION

INDUSTRY LEADING TIER 1 WAREHOUSE MANAGEMENT SYSTEM

- Red Prairie Dispatcher- CS
- Oracle Backend Process
- Photo Image Management Capabilities
- LXE Barcode Scanners
- Online Inventory Request System
- 3rd Party Logistics (3PL)
- ISO 9001-2015 Certified
- ITAR Compliant
- Inventory Accuracy of 99.98%
- On-time Delivery of 99.99%
- Supply Chain Management/Kitting



Centralized Tool Storage

Petersen Inc. allows authorized users the ability to search inventory, order tools, and obtain shipping information online and in real time.

Boeing Performance Excellence Awards
Boeing Supplier of the Year
Boeing Gold Supplier
Boeing Supplier Inspection Delegation

QUALITY CERTIFICATIONS

- NBIC - ("R" Stamp)
- ASME VIII Div. 1 ("U" Stamp)
- ASME VIII Div. 2 ("U2" Stamp)
- ASME Section 1 ("S" Stamp)
- ISO 9001-2015
- AS9100 Rev. D
- NADCAP- Welding
- AISC- Structural Steel Fabrication
- CWB

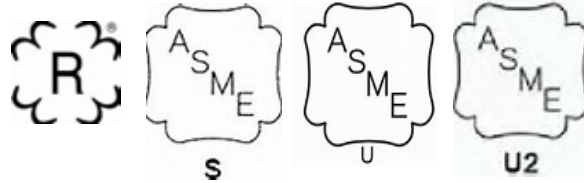

IN COMPLIANCE WITH:

- ASME NQA-1 - Nuclear Facilities
- ASME B31.1- Power Piping
- ASME B31.3- Process Piping
- ASME B31.4 - Pipeline Transport Systems
- ASME B31.8 - Gas Piping Systems
- NRC - Subpart H of 10 CFR Part 71 Packaging & Trans. of Radioactive Materials
- NRC - 10-CFR-50- Appendix B Nuclear Power Plants & Fuel Reprocessing Plants
- ANSI N 14.5- Radioactive Materials Leakage Test
- API 650- Welded Tanks for Oil Storage
- API 1104 - Welding of Pipelines & Related Facilities
- AWS D1.1, D1.2, D1.3, D1.5, D1.6, D17.1



OUR INSPECTION TESTING:

- Radiography
- Magnetic Particle
- Liquid Penetrant
- Ultra Sonic
- Hardness
- Leak
- Hydrostatic



FaroArm Inspection



Laser Tracker Inspection



CMM Inspection



In-House Commercial Grade Dedication Lab



Precision Machining

QUALITY

COMMERCIAL GRADE DEDICATION LABORATORY

Complete metal testing to ASTM, ASME, and AWS specifications including:

- Commercial Grade Dedication of material for nuclear applications
- Spectrographic chemical analysis of low alloy steels, stainless steels, nickel base alloys & aluminum (*includes nitrogen and oxygen determination*)
- 60,000 lbf tension/compression testing
- Rockwell hardness
- 300 ft-lb impact testing to minus 80 degrees C
- Macroscopic examination
- Certified radiographic, penetrant, magnetic particle, ultrasonic, and visual examination
- Weld procedure testing
- Weld wire certification including welding of test coupons in accordance with filler material specifications

STATE AND NATIONAL AWARDS

- Boeing Supplier of the Year
- SBA - Region VIII Subcontractor of the Year (Boeing Nominated)
- SBA - Region VIII Subcontractor of the Year (Thiokol Nominated)
- Best of State - Utah Manufacturing, Fabrication
- Ernst & Young Entrepreneur of the Year- Utah
- INC. 500/5000 list of fastest growing companies
- Utah MEP Manufacturer of the Year
- Utah Best of Business
- Safety Award - Workers' Compensation of Utah
- Company of the Year- Utah Economic Summit

THE PETERSEN WAY

Petersen Inc. has a unique way of doing business. We like to call it "The Petersen Way" or TPW. Our key goals are to improve the lives of our customers, improve the lives of our employee owners (Petersen Inc. is 100% employee owned) and their families, as well as support and give back to the communities in which we live and work. The Petersen Operating Way or POW is the key gear in our operations that drives improvement throughout all areas of Petersen Inc. Without it, we are unable to achieve our key goals. A detailed explanation of the Petersen Operating Way is provided on the next page.

We also track 6 Key Performance Indicators (KPI's) that evaluate our success at reaching efficiency targets. These targets include safety, quality, delivery, employee morale, cost, and smart growth. By tracking these KPI's, we will be successful more often and create the opportunity to win every day.



The Petersen Operating Way is the key gear in our operations that drives improvement throughout all areas of Petersen Incorporated.

THE PETERSEN OPERATING WAY



The Petersen Operating Way (POW) is a method of continuous improvement to enhance the value we provide to our customers. It is a culture to create ideas throughout all levels of the company. The POW enables team members to work together to solve problems and refine all aspects of our business. The 6 key elements are:

- Strategic Development
- Visualization
- Daily Improvement
- Loop Closure
- Problem Solving
- Best Practice Sharing

Strategic Deployment

What does it mean to be successful? Clearly align expectations of what it means to win at each level of the organization, coupled with aligned strategies, tactics, and actions that support goal attainment.

- Strategy Connection Tool
- Catchball Process
- Huddle Boards
- One-on-One's

Visualization

How do we know we are successful? Systems and processes are designed to help leaders and team members see gaps in performance and problems in real-time.

- Huddle Boards
- Leading & Lagging Measures
- 5S
- Process Signals

Daily Improvement

If we have gaps, what are we doing about them? Employees are engaged through team-based problem-solving, idea generation, and recognition.

- Idea Boards
- Implemented Idea Targets
- Idea Celebration/ Employee Recognition
- KATA Process
- Improvement Workshops

Loop Closure

How can we help our team be more successful? Leaders support team members by creating standards, process indicators and feedback systems to ensure procedural effectiveness.

- Return to Green (RTG) Plans
- Action Register
- Leader Standard Works
- Daily Tiered Escalation
- STAR Card Audits

Problem Solving

How do we approach problems? Deploy consistent methodologies and engage teams in scientific problem-solving.

- PCAR, Cause & Corrective Action
- Long/Short-Term Preventative Actions
- Utilize 5 Why's and Fish Bone
- Resolve Systematic Issues
- Living Pareto Charts

Best Practice Sharing

How do we innovate? Utilize tools to identify innovative breakthrough approaches that increase value in the organization.

- Strategy Deployment Process
- Cross Training Matrix
- Leadership Meetings
- Lessons Learned



PETERSEN
INCORPORATED

"A Winning Combination."

CORPORATE FACILITY

635,000 sq. ft.

1527 North 2000 West

Ogden, UT 84404

(801) 732-2000 Phone

(800) 410-6789 Toll-Free

(801) 732-2098 Fax

WAREHOUSING FACILITY

1.4 million sq. ft.

222 North 1140 West

Ogden, UT 84404

(801) 732-2000 Phone

(800) 410-6789 Toll-Free

(801) 337-0673 Fax

IDAHO FACILITY

73,000 sq. ft.

1463 Fortress

Pocatello, ID 83204

(208) 235-6046

(800) 410-6789 Toll-Free

(208) 237-2589 Fax

www.peterseninc.com
sales@peterseninc.com